

**Concept-Development  
Practice Page** **6-3**

**Racing Day with  $a = F/m$**

In each situation below, Cart A has a mass of **1 kg**. Circle the correct answers (A, B, or Same for both).

1. Cart A is pulled with a force of **1 N**.  
Cart B also has a mass of **1 kg** and is pulled with a force of **2 N**.  
Which undergoes the greater acceleration?

(A) **(B)** (Same for both)

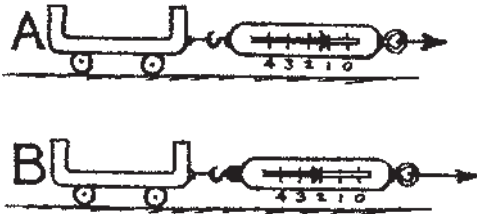

2. Cart A is pulled with a force of **1 N**.  
Cart B has a mass of **2 kg** and is also pulled with a force of **1 N**.  
Which undergoes the greater acceleration?

**(A)** (B) (Same for both)

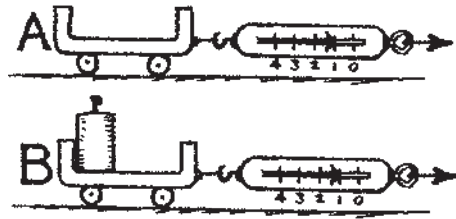

3. Cart A is pulled with a force of **1 N**.  
Cart B has a mass of **2 kg** and is pulled with a force of **2 N**.  
Which undergoes the greater acceleration?

(A) (B) **(Same for both)**

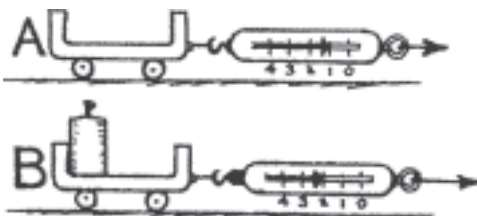

4. Cart A is pulled with a force of **1 N**.  
Cart B has a mass of **3 kg** and is pulled with a force of **3 N**.  
Which undergoes the greater acceleration?

(A) (B) **(Same for both)**

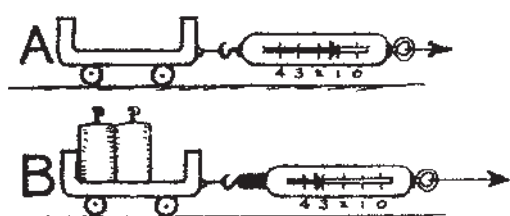

5. This time Cart A is pulled with a force of **4 N**.  
Cart B has a mass of **4 kg** and is pulled with a force of **4 N**.  
Which undergoes the greater acceleration?

**(A)** (B) (Same for both)

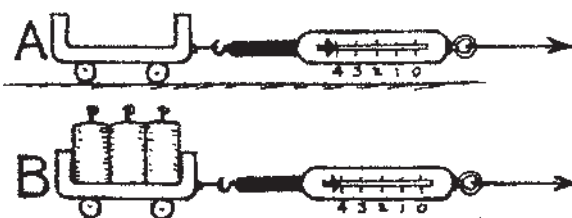

6. Cart A is pulled with a force of **2 N**.  
Cart B has a mass of **4 kg** and is pulled with a force of **3 N**.  
Which undergoes the greater acceleration?

**(A)** (B) (Same for both)

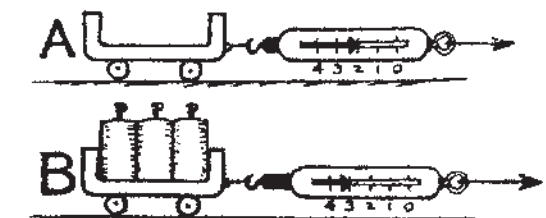

thanx to Dean Baird

© Pearson Education, Inc., or its affiliate(s). All rights reserved.

**CONCEPTUAL PHYSICS**

## Drop and Pull

1. Consider a 1-kg cart being pulled by a 10-N applied force. According to Newton's second law, acceleration of the cart is

$$a = \frac{F}{m} = \frac{10 \text{ N}}{1 \text{ kg}} = 10 \text{ m/s}^2.$$



This is the same as the acceleration of free fall,  $g$ —because a force equal to the cart's weight accelerates it.



2. Consider the acceleration of the cart when the applied force is due to a 10-N iron weight attached to a string draped over a pulley. Will the cart accelerate as before, at  $10 \text{ m/s}^2$ ? The answer is no, because the mass being accelerated is the mass of the cart *plus* the mass of the piece of iron that pulls it. Both masses accelerate. The mass of the 10-N iron weight is 1 kg—so the total mass being accelerated (cart + iron) is 2 kg. Then,

$$a = \frac{F}{m} = \frac{10 \text{ N}}{2 \text{ kg}} = 5 \text{ m/s}^2.$$

The pulley changes only the direction of the force.

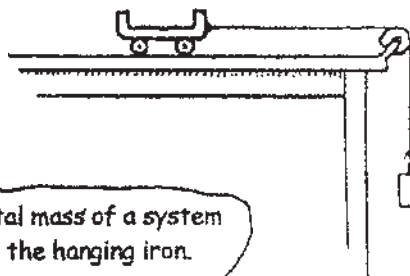

Don't forget; the total mass of a system includes the mass of the hanging iron.



Note this is half the acceleration due to gravity alone,  $g$ . So the acceleration of 2 kg produced by the weight of 1 kg is  $g/2$ .



- a. Find the acceleration of the 1-kg cart when two identical 10-N weights are attached to the string.

$$a = \frac{F}{m} = \frac{\text{applied force}}{\text{total mass}} = \frac{20 \text{ N}}{3 \text{ kg}} = 6.7 \text{ m/s}^2$$

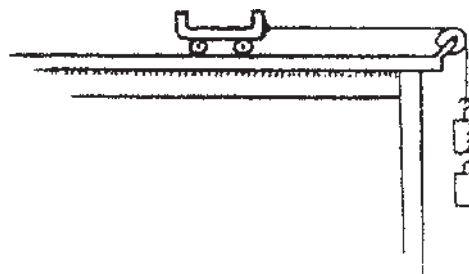

Here we simplify and say  $g = 10 \text{ m/s}^2$ .



## CONCEPTUAL PHYSICS

**Drop and Pull—continued**

- b. Find the acceleration of the 1-kg cart when three identical 10-N weights are attached to the string.

$$a = \frac{F}{m} = \frac{\text{applied force}}{\text{total mass}} = \frac{30 \text{ N}}{4 \text{ kg}} = 7.5 \text{ m/s}^2$$

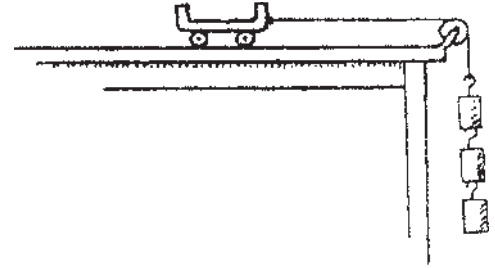



- c. Find the acceleration of the 1-kg cart when four identical 10-N weights (not shown) are attached to the string.

$$a = \frac{F}{m} = \frac{\text{applied force}}{\text{total mass}} = \frac{40 \text{ N}}{5 \text{ kg}} = 8 \text{ m/s}^2$$

- d. This time 1 kg of iron is added to the cart, and only one iron piece dangles from the pulley. Find the acceleration of the cart.

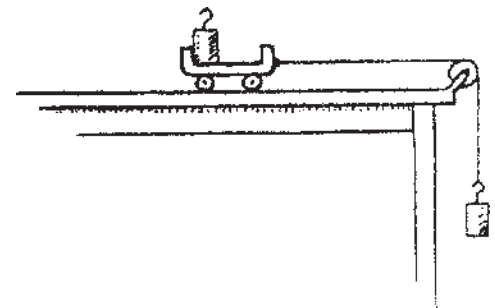
$$a = \frac{F}{m} = \frac{\text{applied force}}{\text{total mass}} = \frac{10 \text{ N}}{3 \text{ kg}} = 3.3 \text{ m/s}^2$$



 The force due to gravity on a mass  $m$  is  $mg$ .  
So gravitational force on 1 kg is  $(1 \text{ kg})(10 \text{ m/s}^2) = 10 \text{ N}$ .

- e. Find the acceleration of the cart when it carries two pieces of iron and only one iron piece dangles from the pulley.

$$a = \frac{F}{m} = \frac{\text{applied force}}{\text{total mass}} = \frac{10 \text{ N}}{4 \text{ kg}} = 2.5 \text{ m/s}^2$$

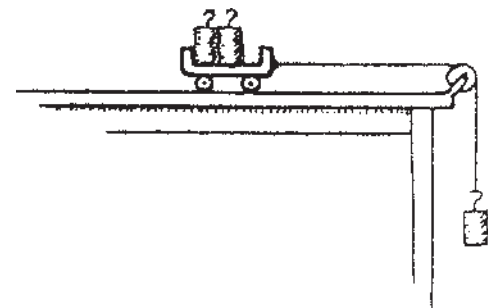

© Pearson Education, Inc., or its affiliate(s). All rights reserved.

**CONCEPTUAL PHYSICS**

- f. Find the acceleration of the cart when it carries 3 pieces of iron and only one iron piece dangles from the pulley.

$$a = \frac{F}{m} = \frac{\text{applied force}}{\text{total mass}} = \frac{10 \text{ N}}{5 \text{ kg}} = 2 \text{ m/s}^2$$

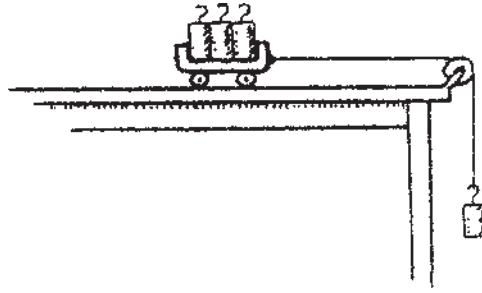

- g. Find the acceleration of the cart when it carries 3 pieces of iron and 4 pieces of iron dangle from the pulley.

$$a = \frac{F}{m} = \frac{\text{applied force}}{\text{total mass}} = \frac{40 \text{ N}}{8 \text{ kg}} = 5 \text{ m/s}^2$$

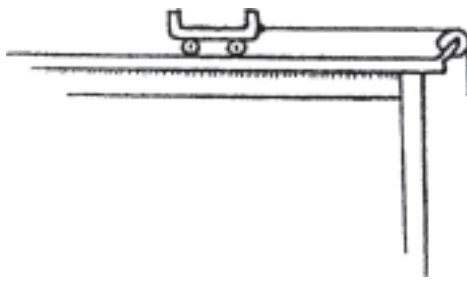
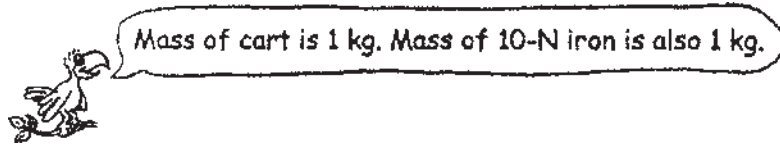
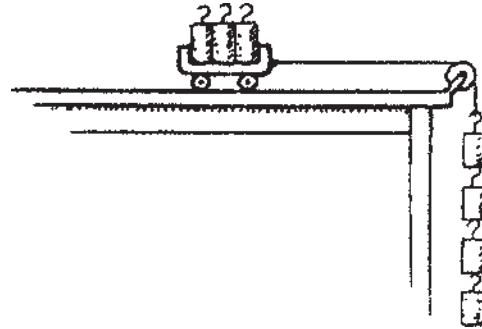

- h. Draw your own combination of masses and find the acceleration.

$$a = \frac{F}{m} = \frac{\text{applied force}}{\text{total mass}} = \text{_____} = \text{_____} \text{ m/s}^2$$

**CONCEPTUAL PHYSICS**